



M.M.E. AIR HOISTS HAI SERIES INDUSTRIAL AIR HOISTS (0.25 to 2 TONNE)



RELIABLE FAST EFFICIENT QUIET LIGHTWEIGHT

LIFTING YOUR WORLD

MME HAI series industrial air hoists are designed specifically for industrial and general engineering applications such as automotive plants, foundries, heat treatment plants, zinc refineries and acid battery manufacturing facilities. The hoists operate at air pressures of between 4 and 6 bar. They comply with the requirements of SANS 1638, ASME B30.16 and EN14492-2. The manufacturing facility producing the hoists is ISO9001 certified.



TECHNICAL SPECIFICATIONS AT 6 bar

MODEL		HAI252	HAI520	HAI1200	HAI12/20
Lifting Capacity (tonne)		0.25	0.5	1.0	2.0
Falls of Chain		1	1	1	2
Chain Size (mm)		7.1 x 21.2	7.1 x 21.2	7.1 x 21.2	7.1 x 21.2
Total Weight (kg) *		25.0	25.0	25.0	32.8
Full Load Lifting Speed (m/min)		22.5	15.0	7.5	3.8
No Load Lifting Speed (m/min)		32.0	29.5	16.0	8.0
Full Load Lowering Speed (m/min)		31.0	36.0	20.4	10.2
No Load Lowering Speed (m/min)		25.0	23.0	13.0	6.5
Air Consumption (m ³ /min)		2.1	2.1	2.1	2.1
Air Connection		G½	G½	G½	G½
Supply Hose (Inside Ø) (mm)		16.0	16.0	16.0	16.0
Sound Level (dB(A))		76	76	76	76
Dimensions (mm)	A	312	312	312	312
	B	216	216	216	216
	C	135	135	135	135
	D	85	85	85	85
	E	196	196	196	196
	F	370	370	370	370
	Min G	420	420	420	-
	Min H	-	-	-	495

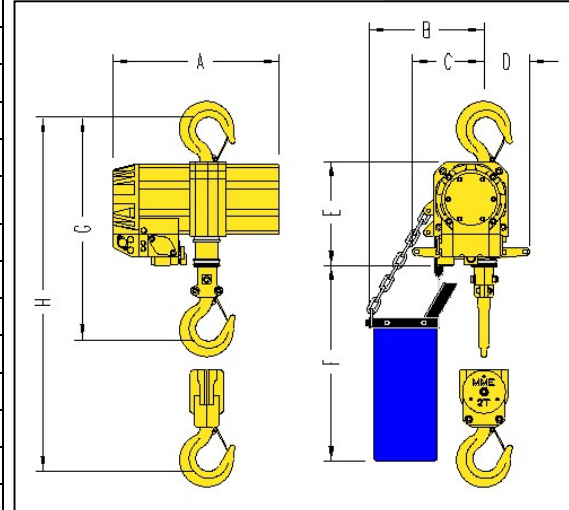

* Weight of includes 3m lift, 2m toggle control. For longer lifts 1.1kg for HAI252, HAI520 and HAI1200 models and 2.2kg for HAI12/20 per metre of lift. For pendent control add 0.8kg.

FEATURES AND CHARACTERISTICS

- Load Limiter** : Integral load limiter which automatically prevents the operator lifting a load in excess of 130% of the working load limit. Load limiter is 100% repeatable at all working pressures and does not wear or generate damaging heat. Standard for lifting capacities of 1 tonne and above.
- Emergency Stop** : All hoists can be supplied with an emergency stop device as an option. This shuts off the main air supply to the hoist when activated. Resetting the device will not automatically restart the hoisting operation.
- Precise Control** : Accurate and precise positioning of loads is standard for both toggle and pendent control models.
- Fail Safe Disc Brake** : Non-asbestos self adjusting disc brake is applied automatically when the air supply to the hoist is shut off. The brake is self adjusting for the life of the brake and is capable of holding in excess of 125% of the working load limit.
- Integral Silencer** : The exhaust air silencer is built into the hoist gearbox housing and limits the noise level to 76dB(A).
- Load Chain** : Grade 8 case hardened, zinc plated load chain ensures stringent high speed duty cycles can be met. The load chain is in accordance with the requirements of EN818-7 and SANS/ISO 3077 Appendix B.
- Vane Motor** : Assisted vane lifting ensures maximum starting torque when starting under load.
- Sealed Gearbox** : The sealed planetary gearbox ensures that the most stringent duty cycles can be met. The gears are heat treated and mounted on high strength, low friction bearings.
- Ease of Maintenance** : The modular design of the hoist allows easy access to internal components such as the motor, gearbox, brake and load limiter. Common parts are used throughout the range.

M.M.E. MANUFACTURING CO. (PTY) LTD
P.O. BOX 355 CARLETONVILLE 2500, SOUTH AFRICA
TEL: +27 (18) 788-6674/5/6 **FAX: +27 (18) 786-1479**
Email: info@mmelifting.com **Website: www.mmelifting.com**